

NL

# HANDLEIDING

## Joy Sport Basic Pro

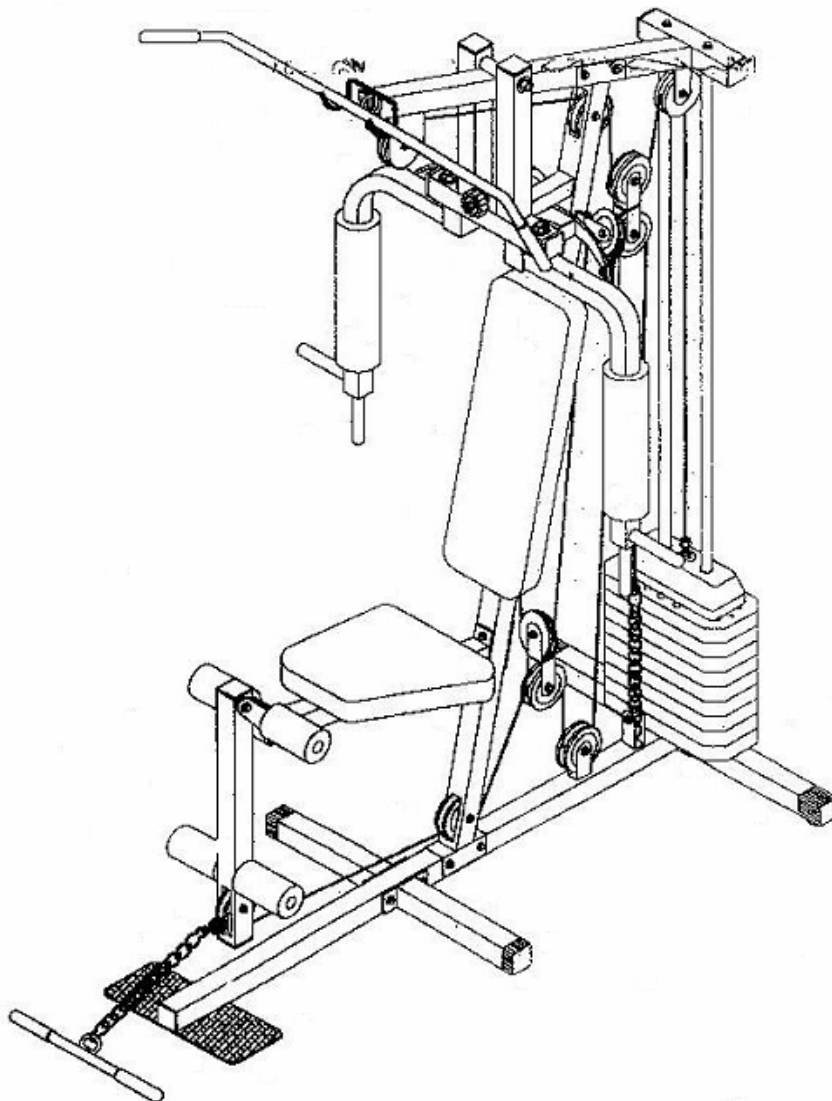

# Joy Sport Importeur

Fitness-Import  
Timmermannsweg 46  
5813 AP Ysselsteyn (LB)  
info@joysport.nl  
www.joysport.nl

## Geachte klant,

Wij feliciteren u met de aankoop van dit **JOY SPORT** product.  
Tevens wensen wij u veel sportplezier toe met uw goede keuze.  
Volg aandachtig de montage handleiding.  
Mocht u nog vragen hebben dan helpen wij u graag verder.

## Garantie,











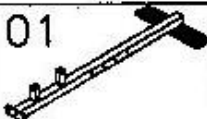
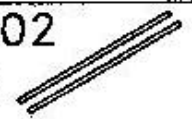

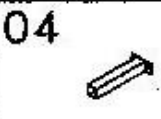
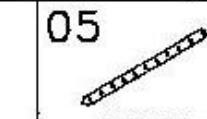

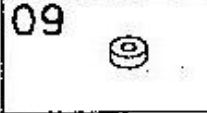
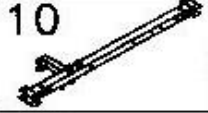
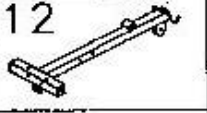
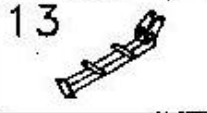

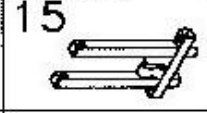
Deze garantie geldt gedurende 12 maanden voor elke fabricagefout aan uw **JOY SPORT** product die door een **JOY SPORT** dealer werd verkocht.  
Wanneer u garantie claimt biedt **JOY SPORT** de mogelijkheid om naar eigen goeddunken het defecte apparaat of het betreffende onderdeel te herstellen of te vervangen.  
De transportkosten van en naar onze werkplaats worden uitgesloten van deze garantie, en zijn dus voor rekening van de bezitter van het product.  
Wanneer u aanspraak wenst te maken op garantie gaat u met het aankoopbewijs naar de dealer waar u uw product heeft gekocht.  
De dealer zal uw claim dan verder afhandelen.

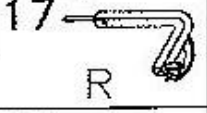
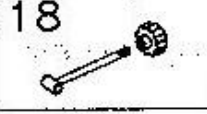
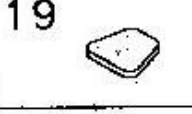
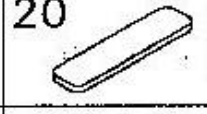
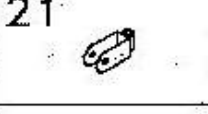
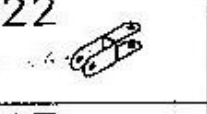
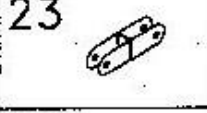
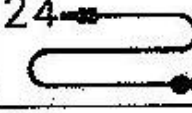
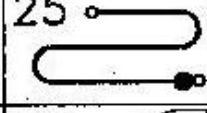
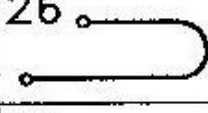
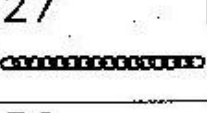
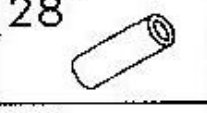
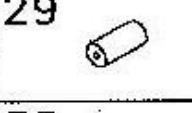
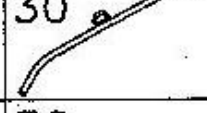
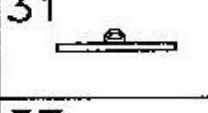
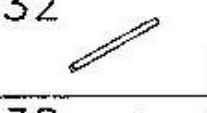
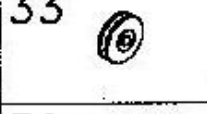
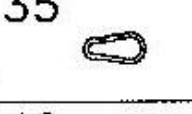
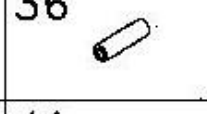
## Garantie uitsluitingen,

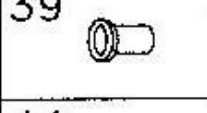
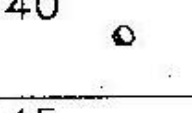
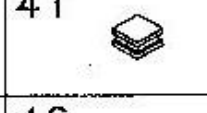
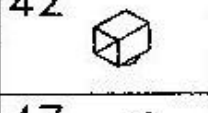
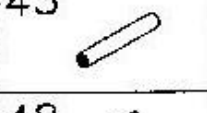
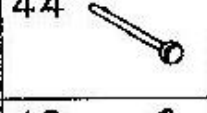
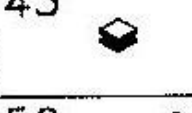
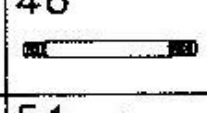
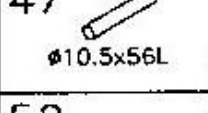
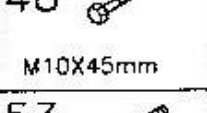
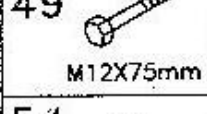
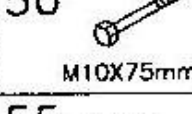
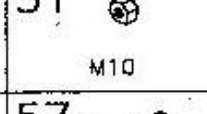
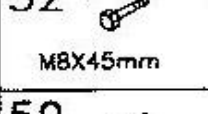
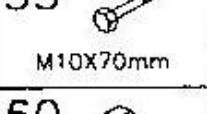
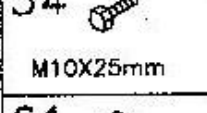
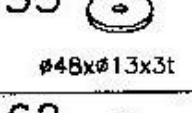
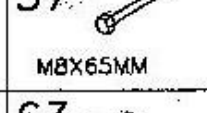
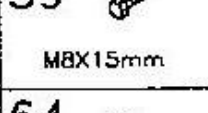
De garantie geldt niet voor: de normale slijtage, de gevolgen van een ondeskundige handeling, of beschadiging door de koper of door derden zelf, en defecten die aan extreme omstandigheden te wijten zijn.  
De garantie kan ook niet worden geclaimd wanneer de originele constructie of uitrusting werd gewijzigd, of wanneer geen originele **JOY SPORT** onderdelen voor de reparatie werden gebruikt.  
De fabrikant kan niet verantwoordelijk gesteld worden voor schade, verlies of kosten, direct of indirect ten gevolg van gebruik van dit apparaat.

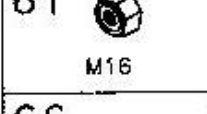
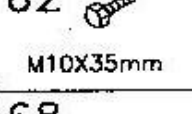
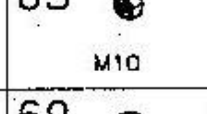
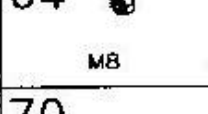
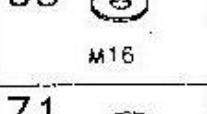
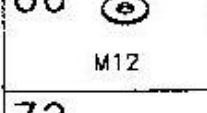
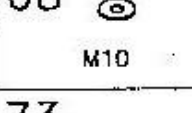
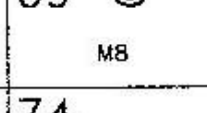
Fitness-Import  
Timmermannsweg 46  
5813 AP Ysselsteyn (LB)  
info@joysport.nl  
www.joysport.nl

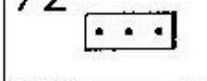
# Onderdelen overzicht.

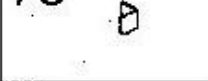
01 	02 	03 	04 	05 
06 	08 	09 	10 	12 
13 	14 	15 	16  L	17  R
18 	19 	20 	21 	22 
23 	24 	25 	26 	27 
28 	29 	30 	31 	32 
33 	35 	36 	37 	38 
39 	40 	41 	42 	43 
44 	45 	46 	47  $\varnothing 10.5 \times 56L$	48  M10X45mm
49  M12X75mm	50  M10X75mm	51  M10	52  M8X45mm	53  M10X70mm
54  M10X25mm	55  $\varnothing 48 \times \varnothing 13 \times 3t$	57  M8X65MM	59  M8X15mm	60  M12
61  M16	62  M10X35mm	63  M10	64  M8	65  M16
66  M12	68  M10	69  M8	70 	71 
72 	73 	74 	75 	

## Onderdelenlijst.

NR.	Naam en Specificatie	Aantal.	NR.	Naam en Specificatie	Aantal.
1	Hoofdframe	1	39	Plastic bus	6
2	Gewichtsgeleiders	2	40	Ronde busje	4
3	Linker Frame	1	41	Afdichtdop (50 mm)	10
4	Rechter Frame	2	42	Rubberen bescherming	2
5	Gewichtspen	1	43	Hand pijp	2
6	Bovenste gewichtplaat	1	44	Gewichtsstang	1
8	Gewichtsplaat	7	45	Afdichtdop (38 mm)	2
9	Rubber dopje	2	46	Pen	1
10	Verticaal frame	1	47	Pen	1
12	Horizontaal frame	1	48	M10 * 45mm	9
13	Zit frame	1	49	M12 * 75mm	1
14	Been curl	1	50	M10 * 75mm	10
15	Steunarm butterfly	1	51	M10 Moer	2
16	Linker butterfly	1	52	M8 * 45mm	1
17	Rechter butterfly	1	53	M10 * 70mm	3
18	Butterfly blokkering	1	54	M10 * 25mm	6
19	Zitting	1	55	OD48mm * ID13mm Ring	1
20	Rug zitting	1	57	M8 * 65mm	5
21	Enkele katrolsteun	2	59	M8 * 15mm	4
22	Dubbele katrolsteun (A)	1	60	M12 Borgmoer	1
23	Dubbele katrolsteun (B)	1	61	M16 Borgmoer	4
24	Kabel (2350 mm)	1	62	M10 * 35mm	2
25	Kabel (3750 mm)	1	63	M10 Borgmoer	24
26	Kabel (2750 mm)	1	64	M8 Borgmoer	4
27	Ketting	2	65	M16 Ring	4
28	Beschermingshoes (Pac deck)	2	66	M12 Ring	2
29	Beschermingshoes (Leg curl)	4	68	M10 Ring	54
30	Bovenste trekbar	1	69	M8 Ring	14
31	Onderste trekbar	1	70	Rubberen afdichting	2
32	Leg curl stang	2	71	Bus	6
33	Katrol	12	72	Stalen plaat	2
35	Haak	4	73	Enkel band	1
36	Handgrip (127 mm)	8	74	Bescherming	2
37	Rubberen aanslag	1	75	Rubberen hoek	2
38	Ronde bus	1			

## STAP 1

1. Plaats de rubberen bescherming (42) op het linker frame (3).
2. Plaats de gewichtgeleider (2) in het linker frame (3).
3. Monteer het hoofdframe (1) vast aan het linker frame (3).
4. Monteer het verticale frame (10) vast aan het hoofdframe (1).

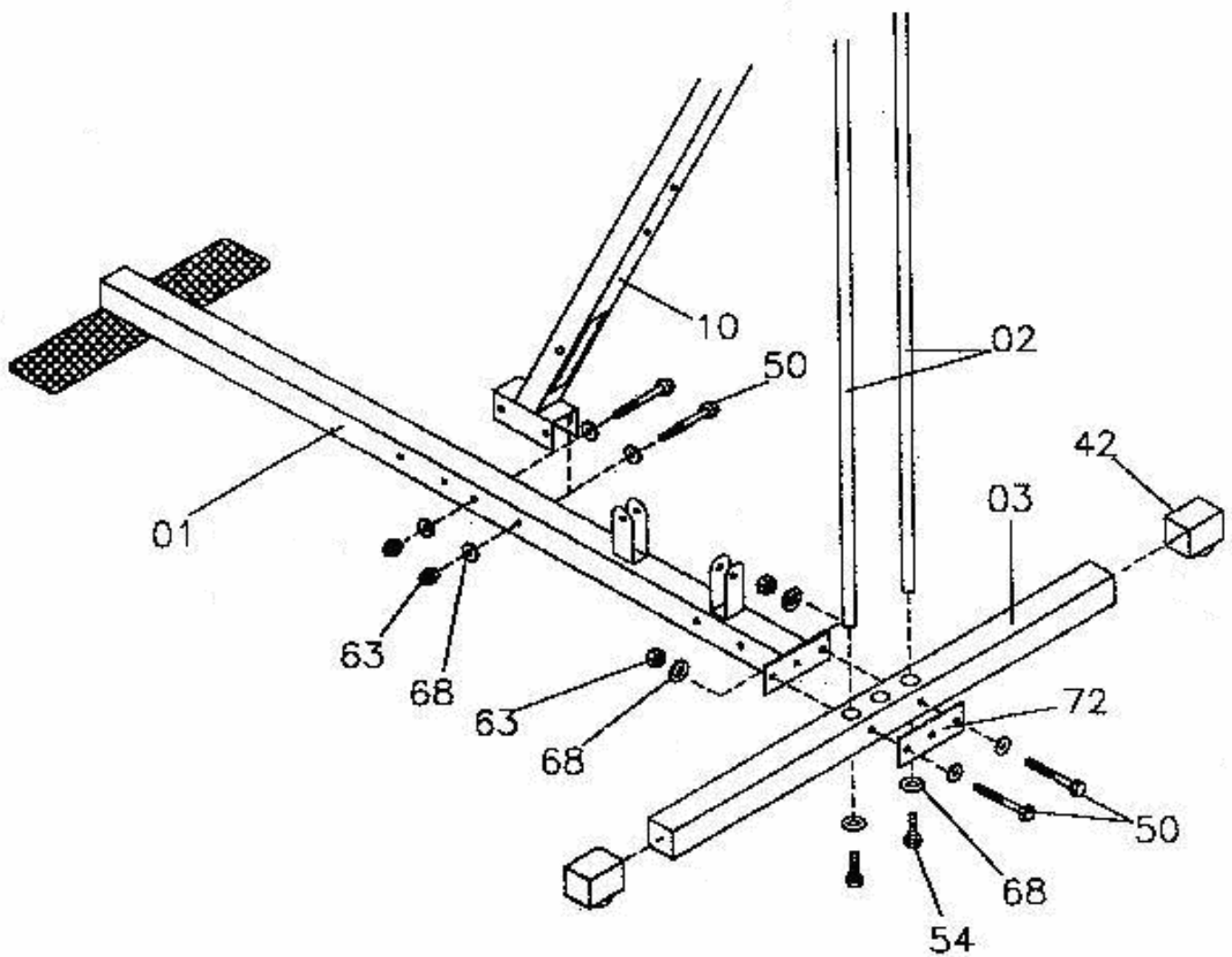

## STAP 2

1. Plaats de rubberen dop (9) over de gewichtgeleiders (2).
2. Schuif nu eerst de 7 gewichtsplaten (8) Bevestig daarna de gewichtspen (5) zoals aangegeven op de tekening hieronder en plaats daarna de bovenste gewichtsplaat (6) over de gewichtgeleider (2).
3. Monteer de 50mm afdichtdop (41) in de voorkant van het hoofdframe (1).
4. Monteer de rubberen afdichting (70) op de twee rechter frames (4).
5. Monteer nu de twee rechter frames (4) aan het hoofdframe (1) zoals aangegeven op de tekening hieronder.

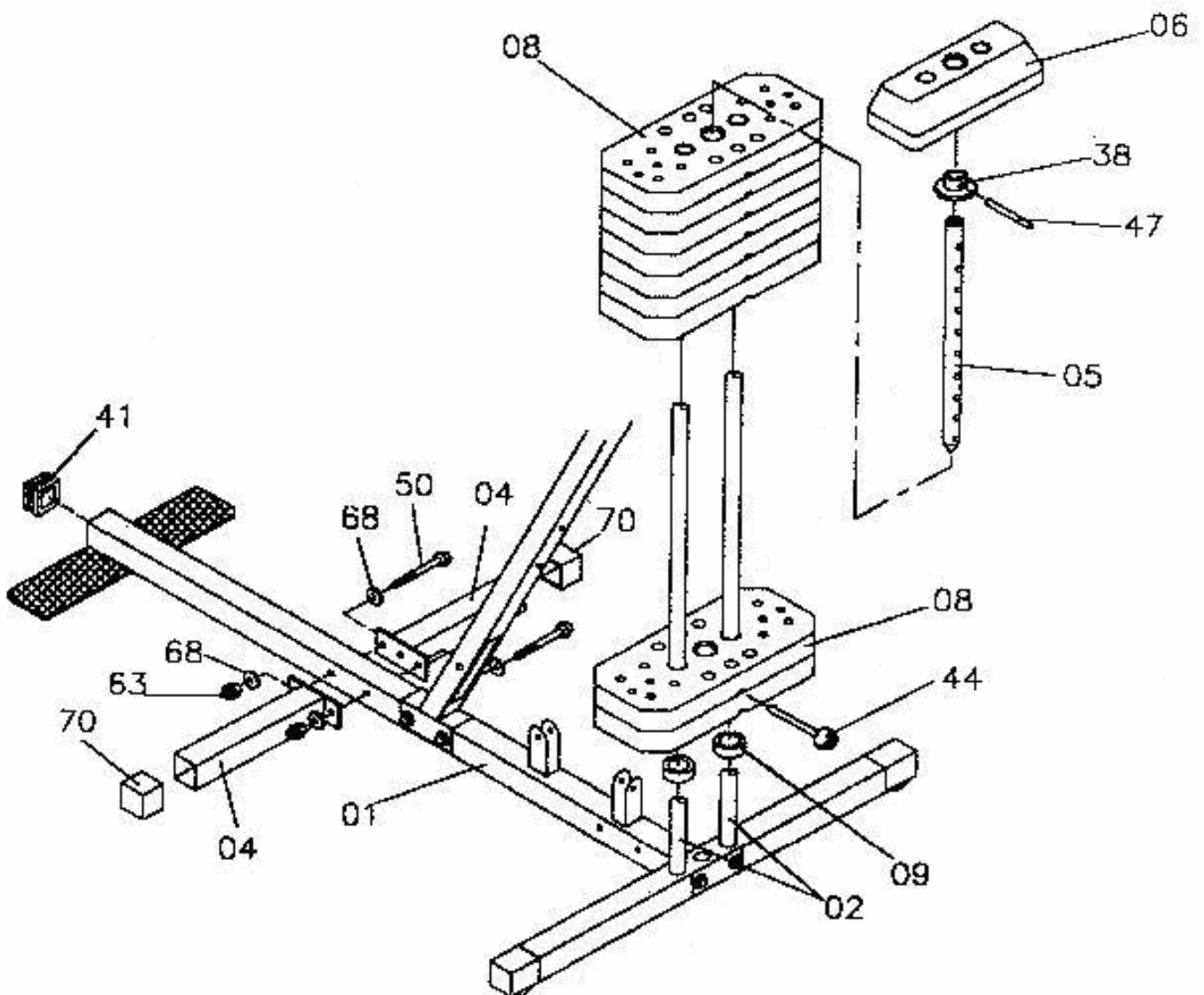

## STAP 3

1. Monteer de 50mm afdichtdoppen (41) in het horizontale frame (12).
2. Monteer het horizontale frame (12) op het verticale frame (10) en monteer de gewichtsgeluiders (2) in het horizontale frame (12) zoals aangegeven op de tekening hieronder.
3. Monteer de rubberen aanslag (37) op het verticale frame (10).
4. Monteer de enkele katrolsteun (21) op het verticale frame (10) gebruik hiervoor een M8\*65mm (57) met een M8 Ring (69) en een M8 Borgmoer (64).
5. Monteer nu de butterfly blokkering (18) op het verticale frame (10) gebruik hiervoor een M8\*65mm (57) met een M8 Ring (69) en een M8 Borgmoer (64).

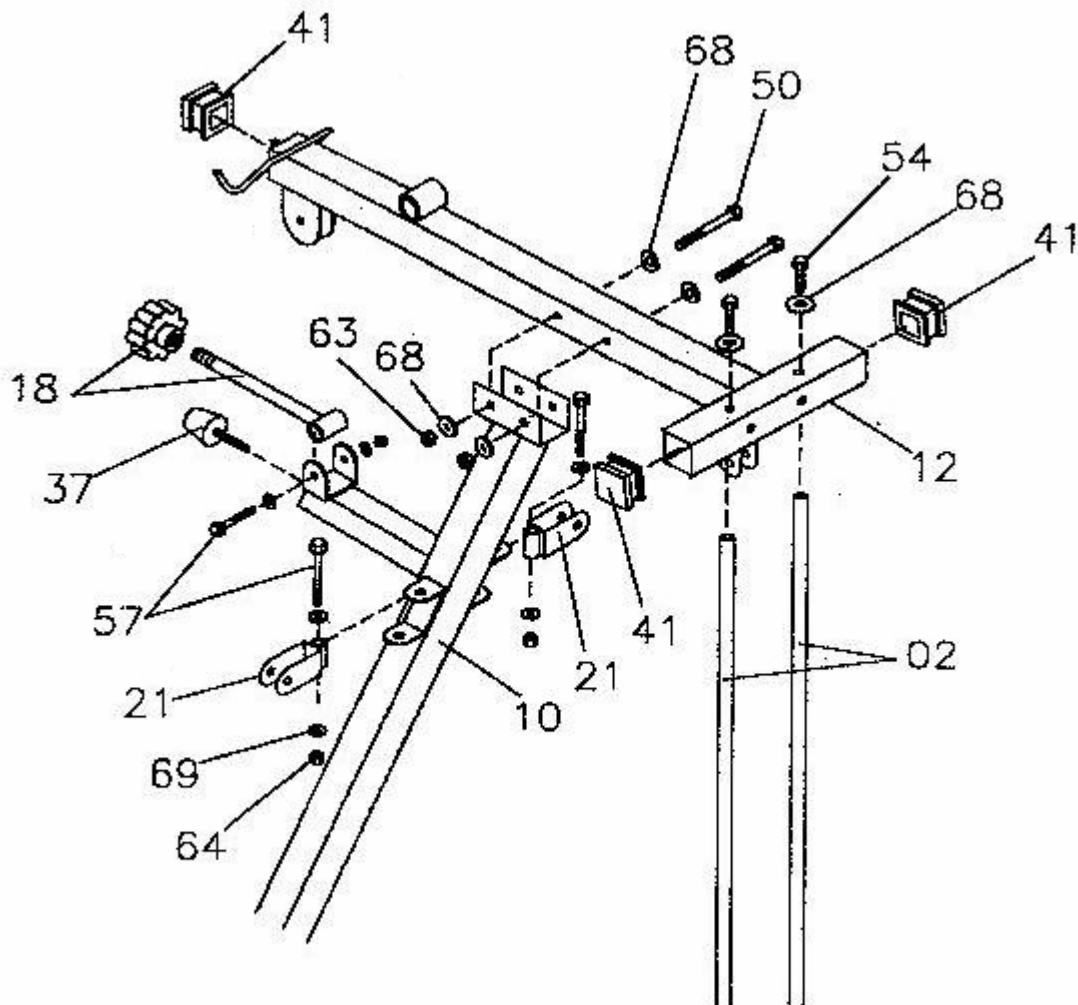

## STAP 4

1. Monteer de 50mm afdichtdoppen (41) in de beencurl (14).
2. Monteer het zit frame (13) op het verticale frame (10) Gebruik hiervoor M10\*75mm (50) , M10 borgmoeren (63) en M10 ringen (68) zoals aangegeven in de tekening hieronder.
3. Monteer nu de beencurl (14) aan het zit frame (13).
4. Monteer de rugzitting (20) op het verticale frame (10).
5. Monteer de zitting (19) op het zit frame (13).
6. Monteer de leg curl stangen (32) in de beencurl (14).
7. Monteer de beschermhoes (29) over de leg curl stang (32).
8. Monteer de ronde busjes (40) in de leg curl stangen (32).

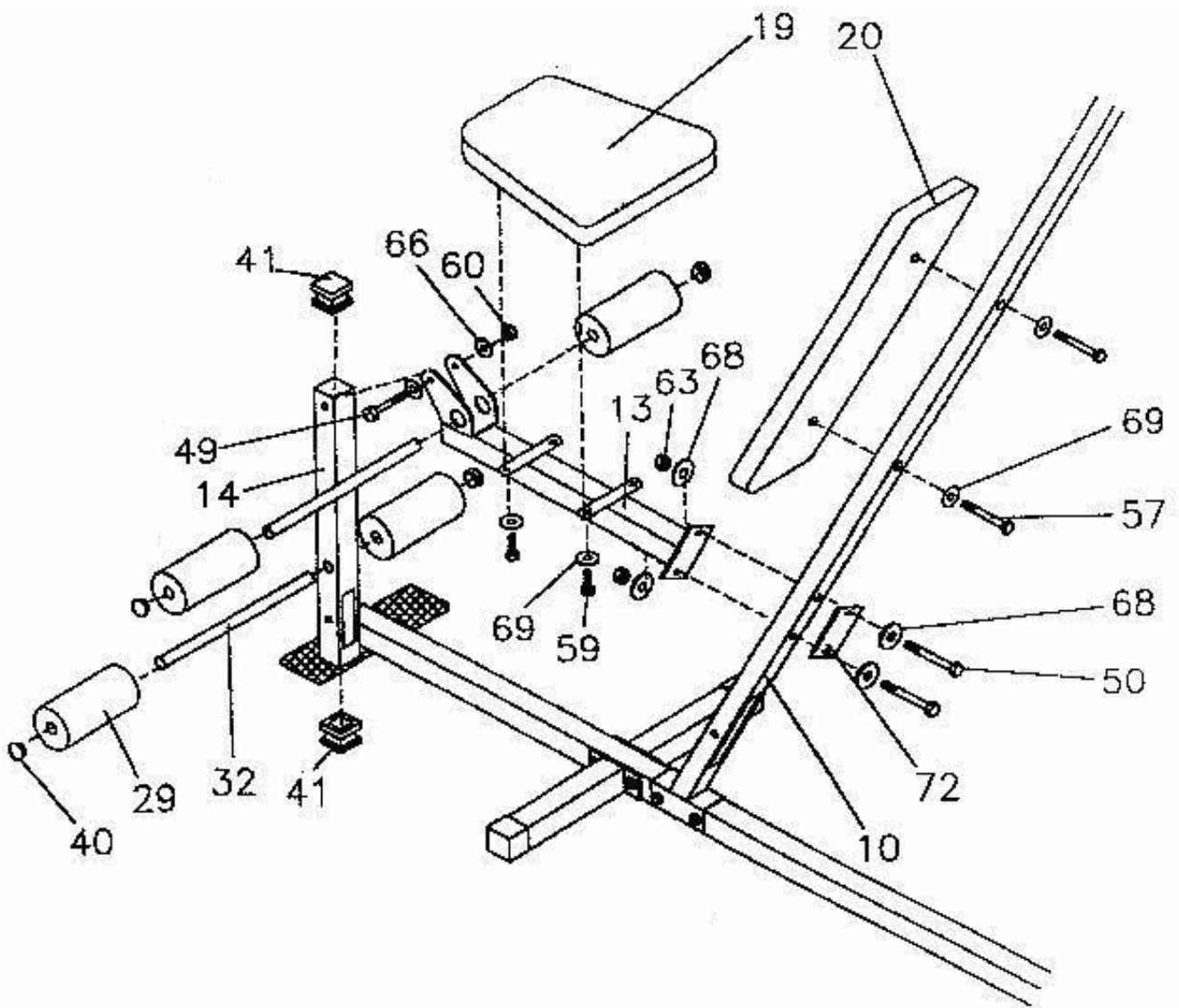

## STAP 5

1. Monteer de 50mm afdichtdoppen (41) in de steunarm butterfly (15).
2. Monteer de bussen (71) in de steunarm butterfly (15) zoals aangegeven op de foto hieronder.

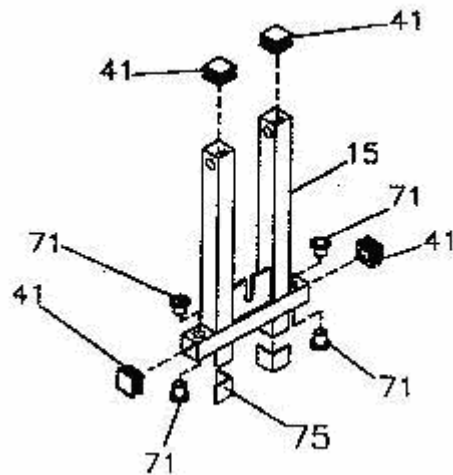

## STAP 6

1. Monteer de steunarm butterfly (15) op het horizontale frame (12) gebruik hiervoor de pen (46) en de bussen (71), ringen (65) en borgmoeren (61) zoals aangegeven in de tekening hieronder.
2. Monteer de beschermhoes (28) over de linker en rechter butterfly (16 & 17).
3. Monteer de handpijp (43) en de handgrip (36) op de linker en rechter butterfly (16 & 17) zoals aangegeven op de tekening hieronder.
4. Monteer de linker en rechter butterfly (16 & 17) aan de steunarm butterfly (15) zoals aangegeven op de tekening hieronder.

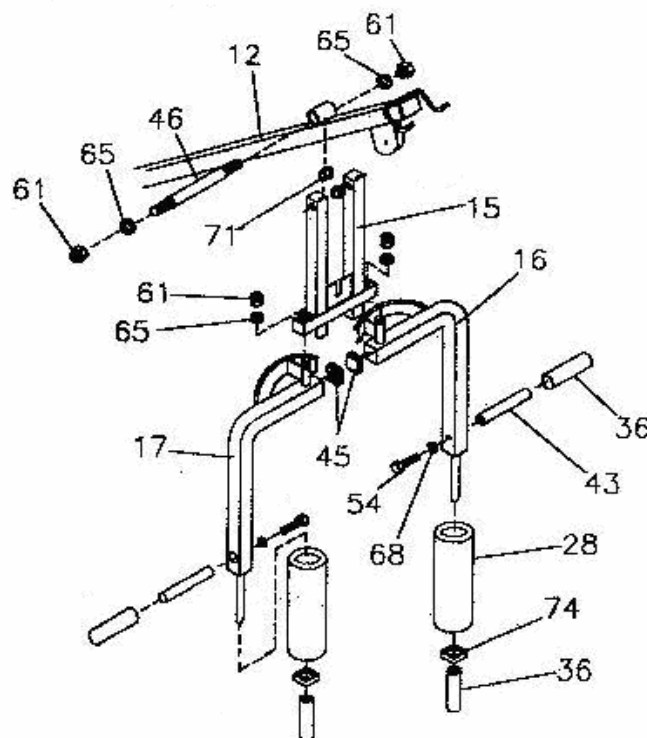

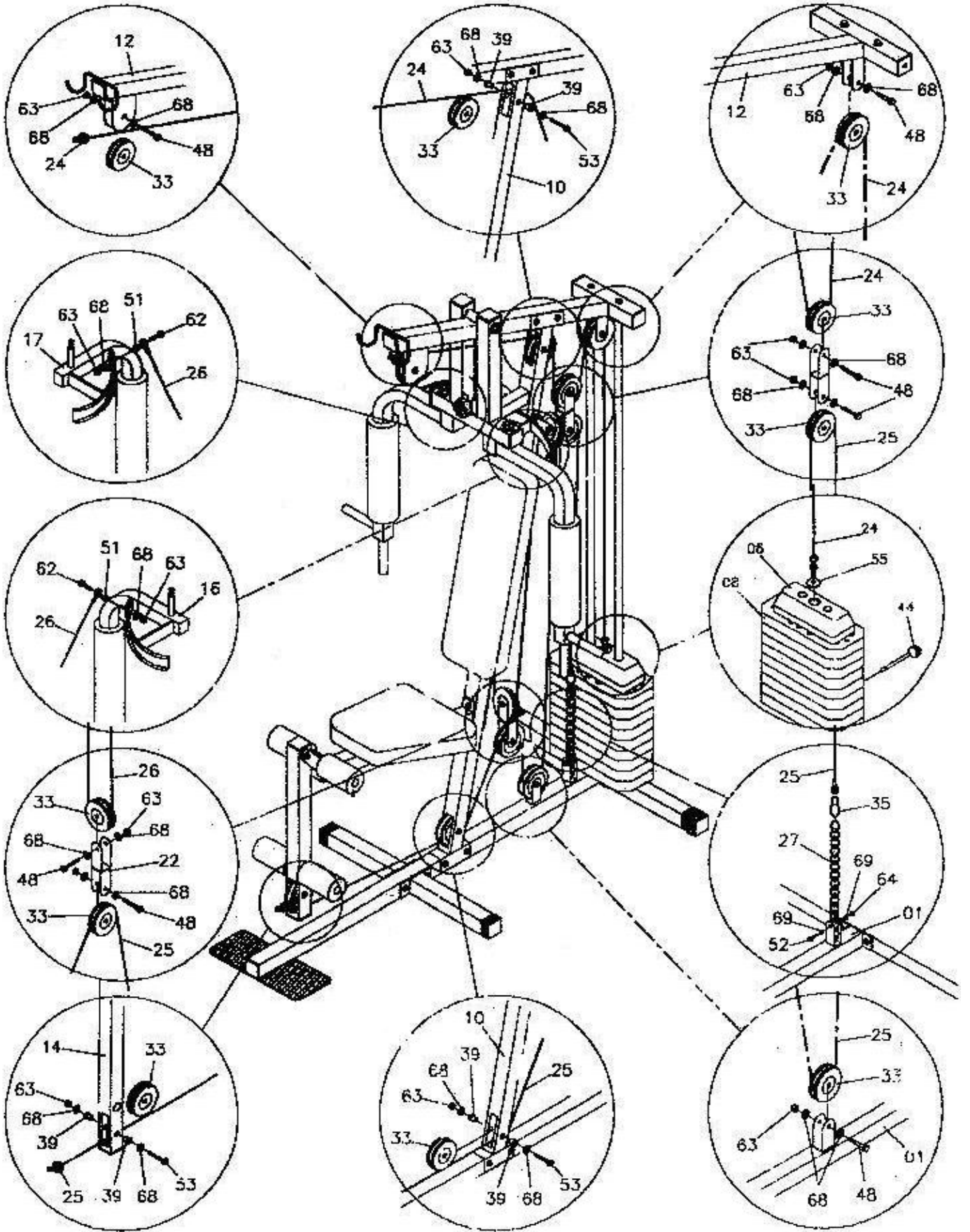

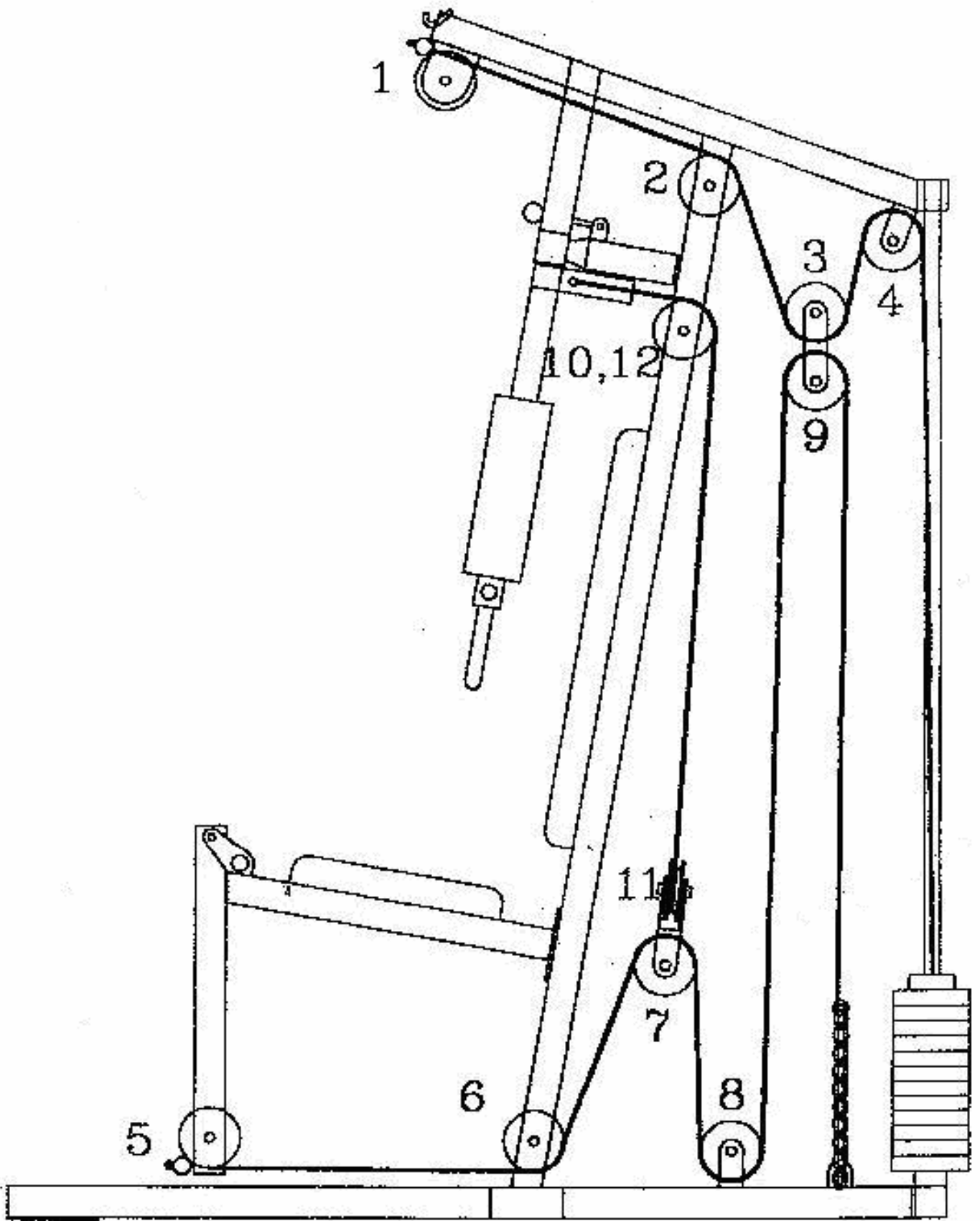



# USER MANUAL

## Joy Sport Basic Pro

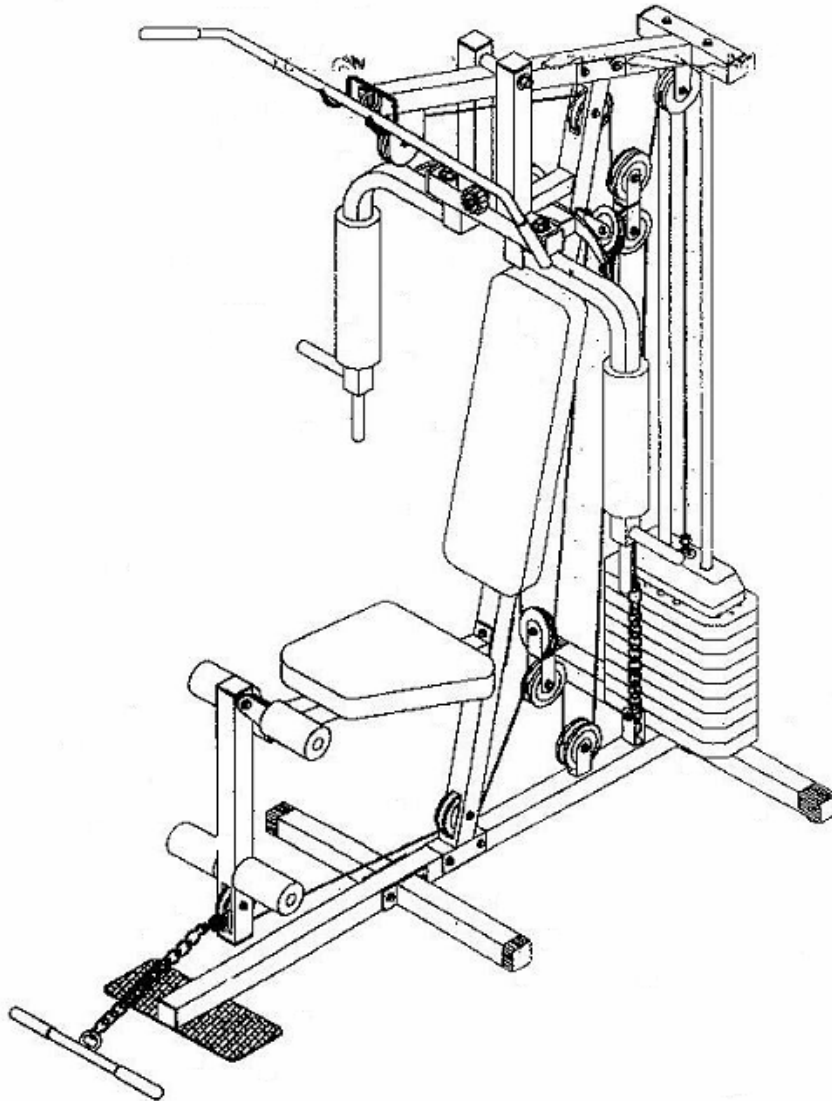

# Joy Sport Importer

Fitness-Import  
Timmermannsweg 46  
5813 AP Ysselsteyn (LB)  
info@joysport.nl  
www.joysport.nl

## Dear customer,

We want to thank you for having chosen a **JOY SPORT** product, and wish you a lot of fun and success during training with your **JOY SPORT** exercisers.

Please note and follow the enclosed safety and assembly instructions carefully.

If you have questions please do not hesitate to contact us.

## Guarantee,

This guarantee covers all manufacturing and material flaws on **JOY SPORT** products purchased from an authorized **JOY SPORT** dealer for a period of 12 months from purchase.

If you wish to make a claim under the guarantee, **JOY SPORT** shall be entitled to repair or replace the defective unit or part at its discretion.

The owner of the unit must pay for the transport costs and any dealer's workshop costs.

To make a claim under the guarantee, take your guarantee card to your dealer.

The dealer will then take the necessary action.

If this is not possible, contact your national **JOY SPORT** importer.











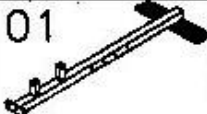
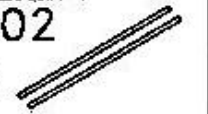

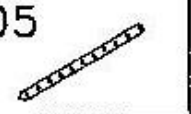



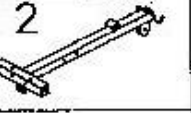
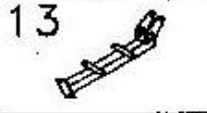

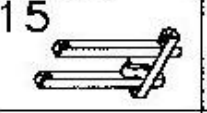
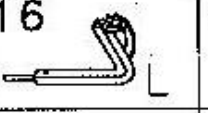
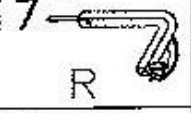
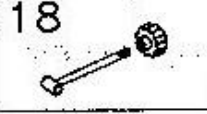
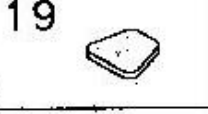
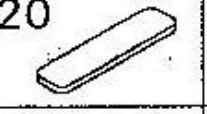
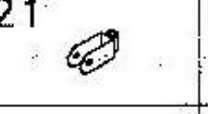
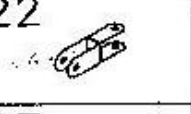
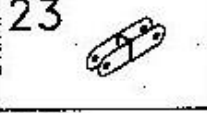
The following are not covered by the guarantee : normal wear and tear and the consequences of improper treatment or damage caused by the purchaser or third persons and faults which are due to other circumstances.

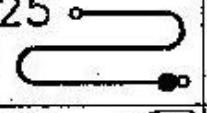
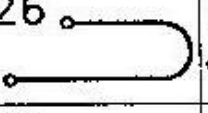
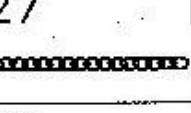
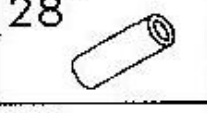
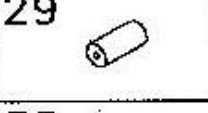
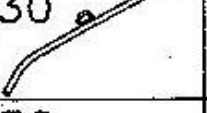
Claims may not be made under the guarantee if modifications have been made to the original construction or equipment or if **JOY SPORT** original parts were not used to repair the unit.

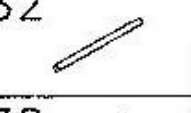
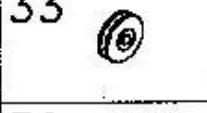
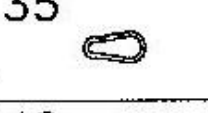
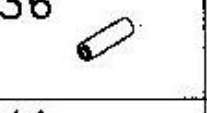
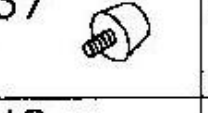
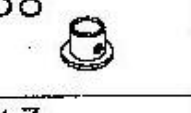
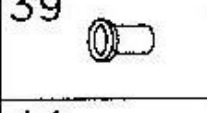
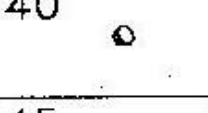
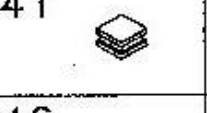
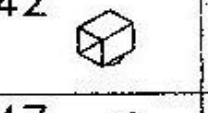
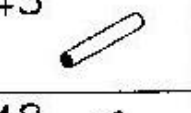
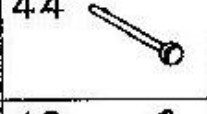
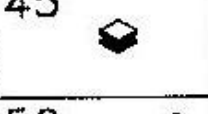
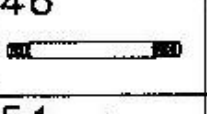
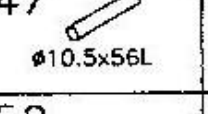
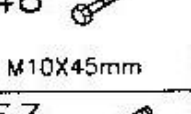
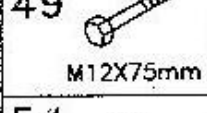
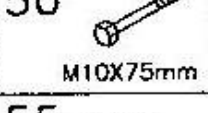
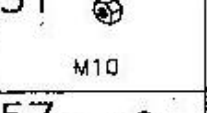
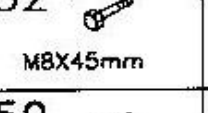
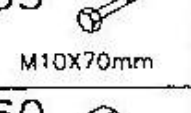
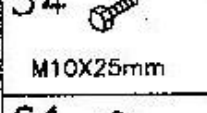
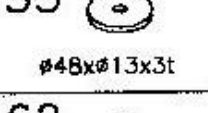
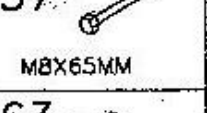
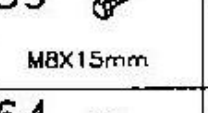
In no event the manufacturer shall be liable for incidental or consequential losses, damages or expenses in connection with exercise products.

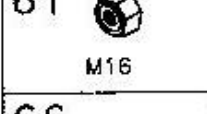
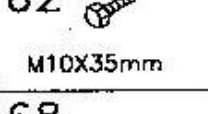
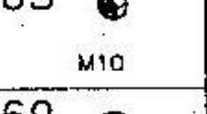
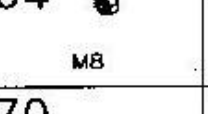
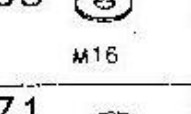
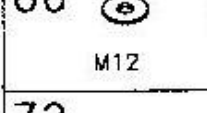
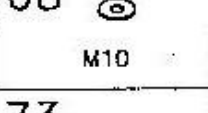
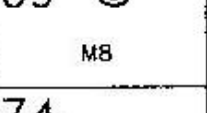
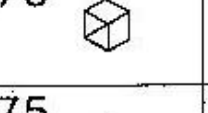
Fitness-Import  
Timmermannsweg 46  
5813 AP Ysselsteyn (LB)  
info@joysport.nl  
www.joysport.nl

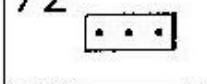
# Onderdelen overzicht.

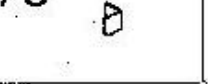
01 	02 	03 	04 	05 
06 	08 	09 	10 	12 
13 	14 	15 	16  L	17  R
18 	19 	20 	21 	22 
23 	24 	25 	26 	27 
28 	29 	30 	31 	32 
33 	35 	36 	37 	38 
39 	40 	41 	42 	43 
44 	45 	46 	47  $\varnothing 10.5 \times 56L$	48  M10X45mm
49  M12X75mm	50  M10X75mm	51  M10	52  M8X45mm	53  M10X70mm
54  M10X25mm	55  $\varnothing 48 \times \varnothing 13 \times 3t$	57  M8X65MM	59  M8X15mm	60  M12
61  M16	62  M10X35mm	63  M10	64  M8	65  M16
66  M12	68  M10	69  M8	70 	71 
72 	73 	74 	75 	

## Part list.

NR.	Name and spec.	Pcs.	NR.	Name and spec.	Pcs.
1	Main base	1	39	Plastic bushing	6
2	Guide rod	2	40	1" Round end cap	4
3	Left base	1	41	50mm Square end cap	10
4	Right base	2	42	Rubber end cap	2
5	Selector shaft	1	43	Handle pipe	2
6	Top plate	1	44	Pin for weight stack	1
8	Weight stack	7	45	38mm Square end cap	2
9	Rubber dount	2	46	Press bar shaft	1
10	Vertical beam	1	47	Quick pin	1
12	Top cross beam	1	48	M10 * 45mm Hex bolt	9
13	Seat assembly unit	1	49	M12 * 75mm Hex bolt	1
14	Leg extension/Arm curl bar	1	50	M10 * 75mm Hex bolt	10
15	Press bar	1	51	M10 Nut	2
16	Left pec deck arm	1	52	M8 * 45mm Hex bolt	1
17	Right pec deck arm	1	53	M10 * 70mm Hex bolt	3
18	Press pin	1	54	M10 * 25mm Hex bolt	6
19	Seat	1	55	OD48mm * ID13mm Washer	1
20	Back seat	1	57	M8 * 65mm Hex bolt	5
21	Pully block	2	59	M8 * 15mm Hex bolt	4
22	Floating pulley block (A)	1	60	M12 Nylon nut	1
23	Floating pulley block (B)	1	61	M16 Nylon nut	4
24	Cable (2350 mm)	1	62	M10 * 35mm Hex bolt	2
25	Cable (3750 mm)	1	63	M10 Nylon nut	24
26	Cable (2750 mm)	1	64	M8 Nylon nut	4
27	Chain	2	65	M16 Washer	4
28	Pec deck pad	2	66	M12 Washer	2
29	Leg extension / Curl pad	4	68	M10 Washer	54
30	Lat bar	1	69	M8 Washer	14
31	Curl bar	1	70	Rubber cap	2
32	Pad holder	2	71	Oil busing	6
33	Pulley	12	72	Steel plate	2
35	Chain hook	4	73	Ankle strap	1
36	Hand grip (127 mm)	8	74	Square cap 26 * 38mm	2
37	Rubber bumper	1	75	Buffer 40*40mm	2
38	1" Round bushing	1			

# STEP 1

- 1. Place rubber cap (42) into both ends of left base (3).
- 2. Insert guide rods (2) to left base (3).
- 3. Attach main base (1) to left base (3) fasten all bolts by using tool.
- 4. Attach verticle beam (10) to mainbase (1).

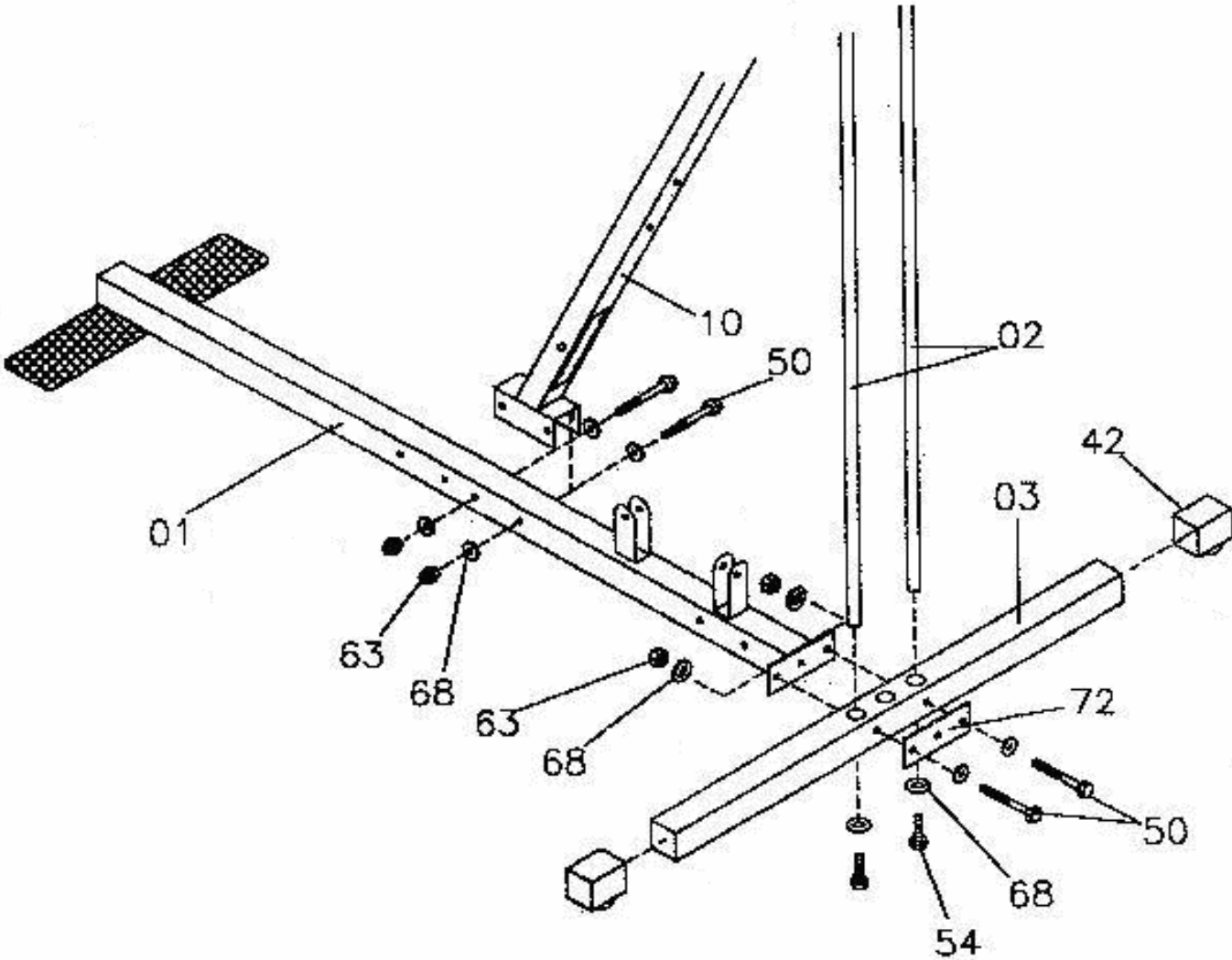

## STEP 2

1. Attach the rubber dount (9) into the guide rod (2).
2. Slide the weight plate (8) and top plate (6) over guide rod (2).  
**Groove for selector pin on weight plates should face down.**
3. Install 1" round bushing (38) into the selector shaft (5) with pin (47) then attach the selector shaft (5) into the top plate (6).
4. Place 50mm square cap (41) into both ends of front base (1).
5. Place rubber cap (70) into both ends of right base (4).
6. Attach right base (4) to main base (1) as shown.

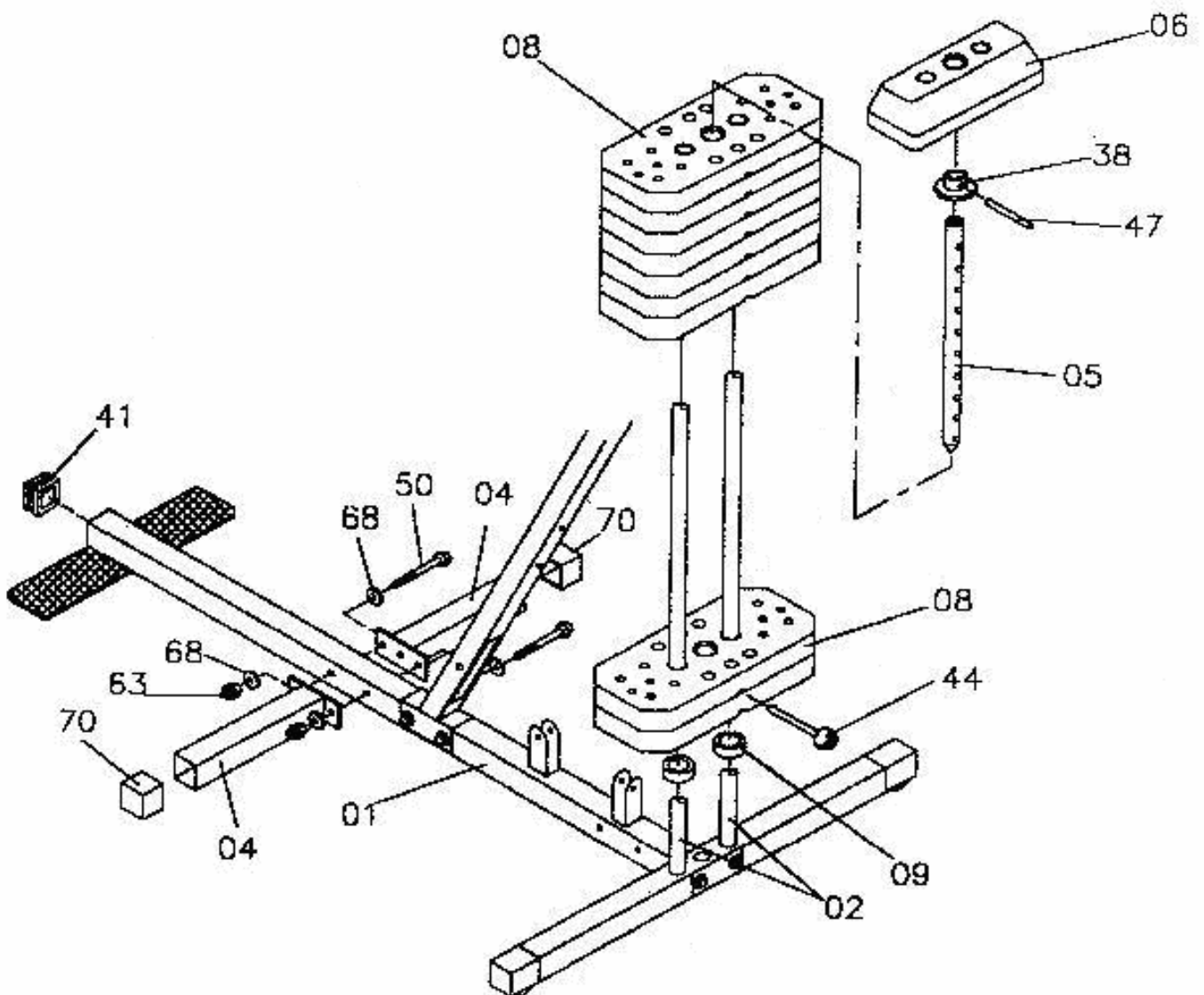

## STEP 3

1. Place 50mm square cap (41) into both ends of top cross beam (12).
2. Attach top cross beam (12) onto the verticle beam (10) from top side and connect the guide rods (2) to the top cross beam (12) as shown.
3. Attach rubber bumper (37) to the verticle beam (10).
4. Attach pulley block (21) to the verticle beam (10), use M8\*65mm bolt (57) with M8 washer (69) and M8 nuts (64).
5. Intsall press pin (18) to the verticle beam (10) with M8\*65mm bolt (57), M8 washer (69) and M8 nuts (64).

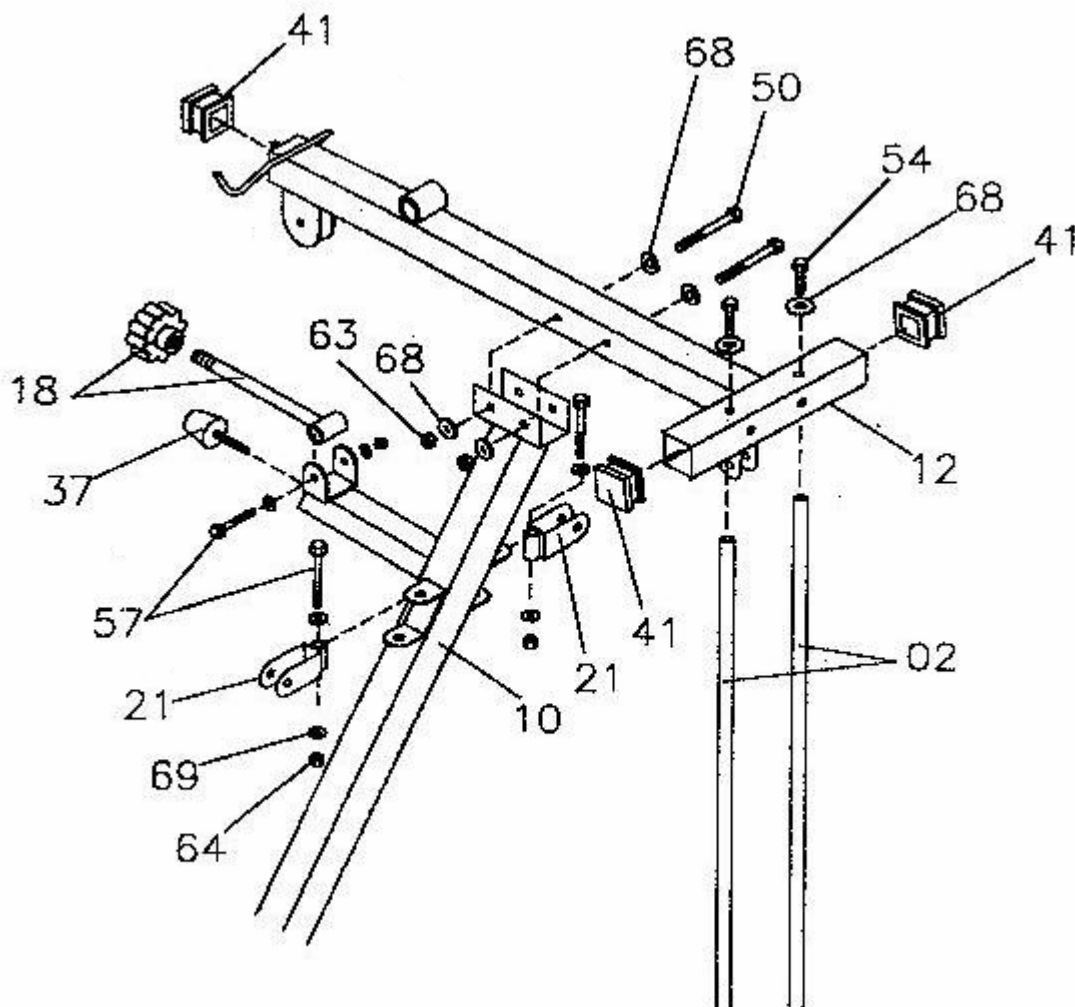

## STEP 4

1. Place 50mm square cap (41) into both ends of leg extension / arm curl bar (14).
2. Attach seat assembly (13) to verticle beam (10), with bolts (50), nuts (63) and washers (68) as shown.
3. Attach leg extension / arm curl bar (14) to seat assembly (13).
4. Attach back seat (20) to verticle beam (10) as shown.
5. Attach seat (19) to seat assembly (13) as shown.
6. Slide pad holders (32) into the hole provided.
7. Slide leg extension/curl pads (29) onto pad holders (32).
8. Place 1" round cap (40) into pad holders (32).

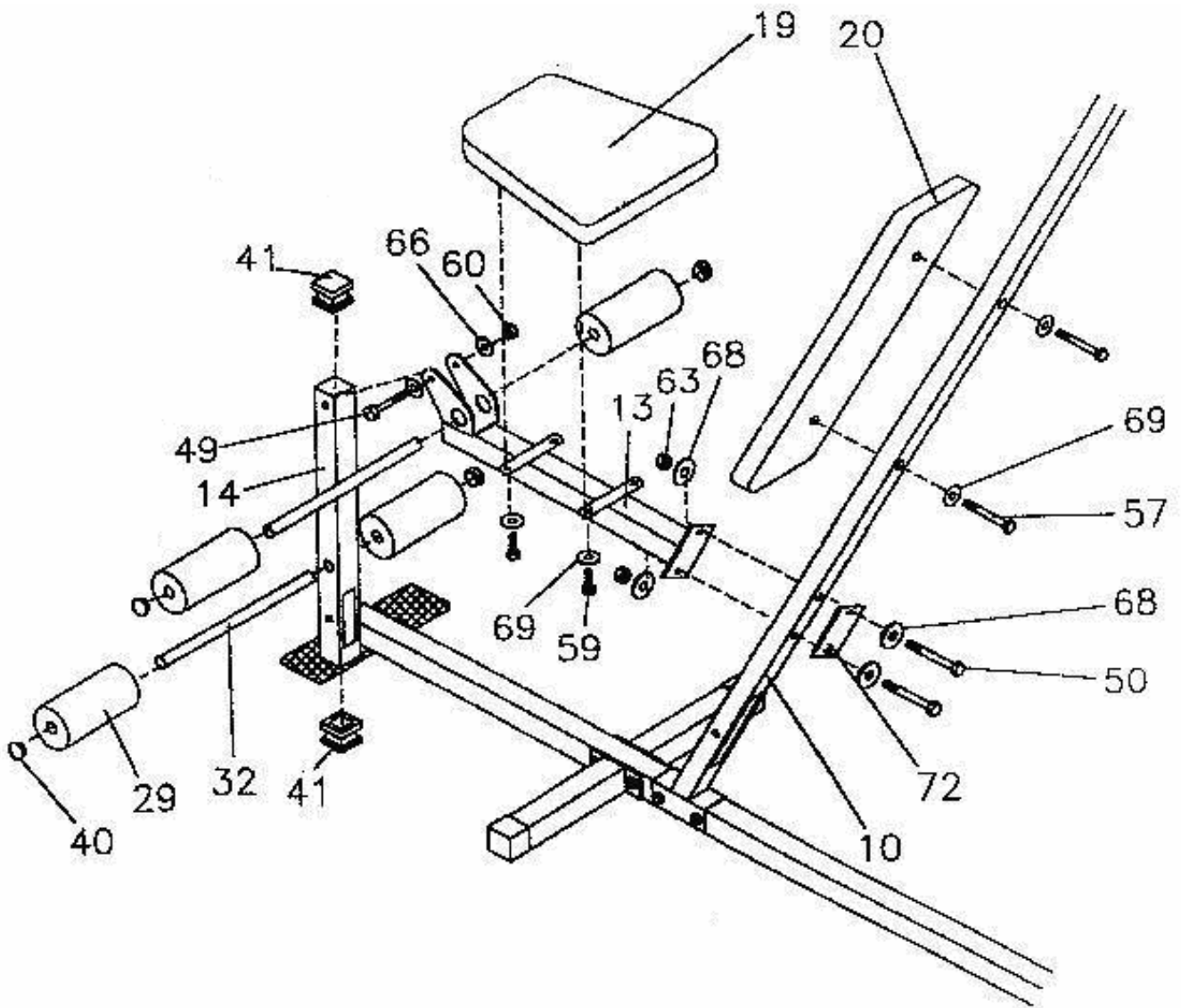

## STEP 5

1. Place 50mm square cap (41) into both ends of press bar (15).
2. Install oil bushing (71) into the press bar (15) as shown.

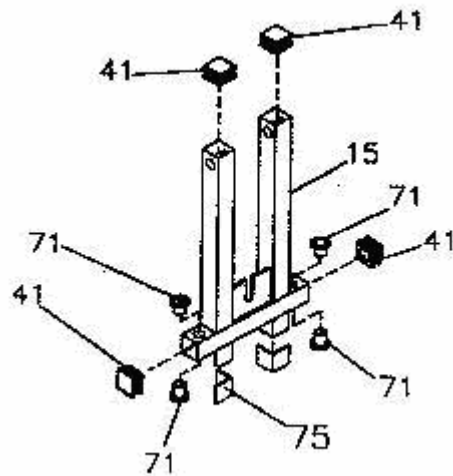

## STEP 6

1. Attach press bar (15) to top cross beam (12) with press bar shaft (46) and oil bushing (71) washer (65) bolt (61) as shown.
2. Attach pec deck pads (28) and hand grip (36) slide onto pec deck arm (16 & 17).
3. Attach handle pipe (43) and hand grip (36) to pec deck arm (16 & 17) with bolt (54), washer (68) as shown.
4. Install pec deck arm (16 & 17) to press bar (15) with washer (65) and nylon nuts (61) as shown.

